

# AT-FL Series

## Dimensions (1-stage, Ratio $i=1\sim5$ )

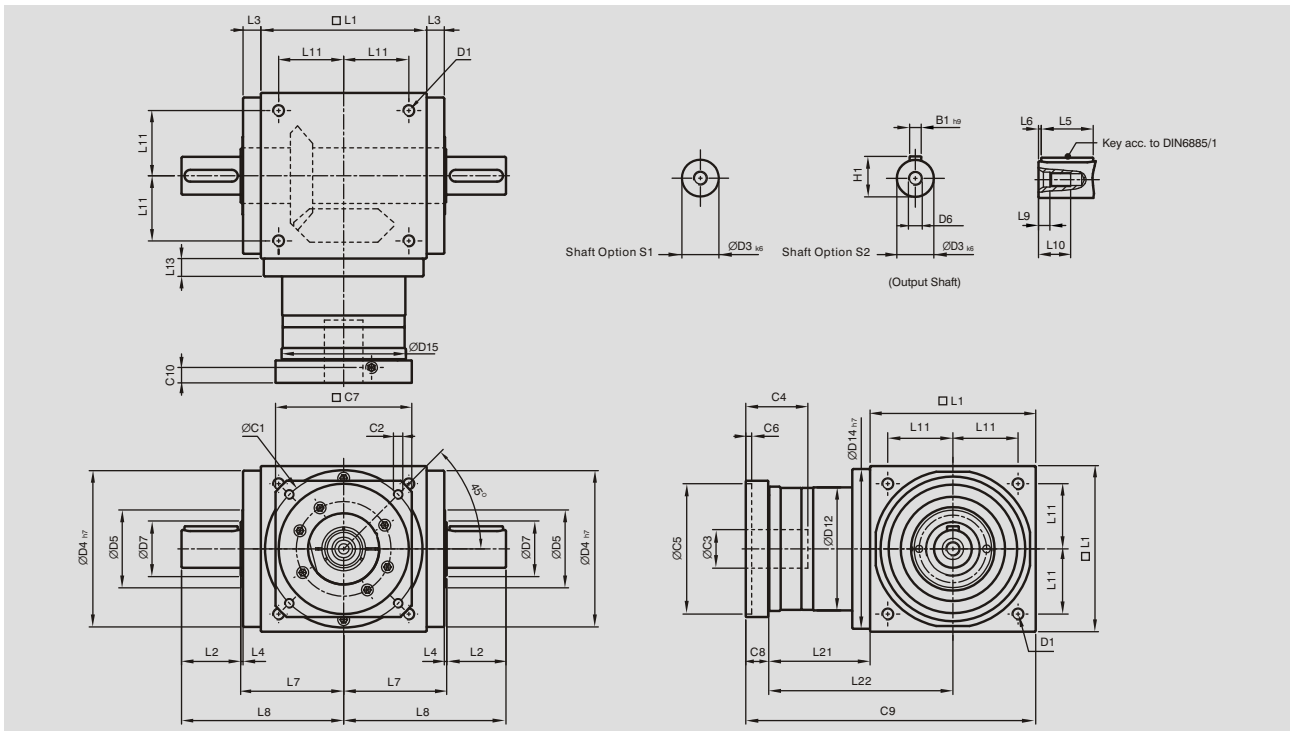

[unit: mm]

Dimension	AT065 FL	AT075 FL	AT090 FL	AT110 FL	AT140 FL	AT170 FL	AT210 FL	AT240 FL	AT280 FL
D1	M4	M6	M6	M8	M10	M12	M16	M16	M16
D3 <sub>k6</sub>	13	16	18	22	32	40	50	55	60
D4 <sub>h7</sub>	63	73	88	108	135	165	205	235	275
D5	31	35	43	53	68	83	104	124	144
D6	M4	M5	M5	M8	M12	M16	M16	M16	M20
D7	21	22	28	33	47	55	75	85	110
D12	62	72	86	106	104	128	160	180	200
D14 <sub>h7</sub>	63	73	88	108	135	165	205	235	275
D15	62.9	72.9	87	107	105	127	158	178	198
L1	65	75	90	110	140	170	210	240	280
L2	19.5	30	35	40	50	60	75	85	110
L3	13	14.5	15	15	15	15	20	25	25
L4	2	2	2	2	2	2	2	2	2
L5	16	25	28	32	45	50	70	80	100
L6	2	2.5	3.5	4	2.5	5	2.5	2.5	5
L7	47.5	54	62	72	87	102	127	147	167
L8	67	84	97	112	137	162	202	232	277
L9	4.5	4.8	4.8	7.2	10	12	12	12	15
L10	10	12.5	12.5	19	28	36	36	36	42
L11	27	30	36	44	55	67	85	95	110
L13	13	15	15	15	15	15	20	25	25
L21	49	60.5	63	69.5	85.5	95	130	144.5	135
L22	81.5	98	108	124.5	155.5	180	235	264.5	275
C1 <sup>3</sup>	46	70	100	100	130	165	215	215	235
C2 <sup>3</sup>	M4	M5	M6	M6	M8	M10	M12	M12	M12
C3 <sup>3</sup>	★ ≤11 / ≤12	★ ≤14 / ≤15.875 / ≤16	≤19	≤24	≤32	≤38	≤42	≤48	≤55
C4 <sup>3</sup>	30	34	40	40	50	60	85	85	116
C5 <sup>3</sup>	30	50	80	80	110	130	180	180	200
C6 <sup>3</sup>	3.5	8	4	4	5	6	6	6	6
C7 <sup>3</sup>	42	60	90	90	115	142	190	190	220
C8 <sup>3</sup>	19.5	19	17	17	19.5	22.5	29	29	63
C9 <sup>3</sup>	133.5	154.5	170	196.5	245	287.5	369	413.5	478
C10 <sup>3</sup>	13.25	13.5	10.75	10.75	13	15	20.75	20.75	53.5
B1 <sub>h9</sub>	5	5	6	6	10	12	14	16	18
H1	15	18	20.5	24.5	35	43	53.5	59	64

3. C1~C10 are motor specific dimensions (metric std shown). Refer to Apexdyna.com and Design Tool to view your specific motor mounting system.

★ AT065 FLM1 offers C3 ≤12 option. ★ AT075 FLM1 offers C3 ≤16 option. ★ AT075 FLM2 offers C3 ≤15.875 option.

# AT-FL Series

## Dimensions (2-stage, Ratio $i=7\sim 50$ )

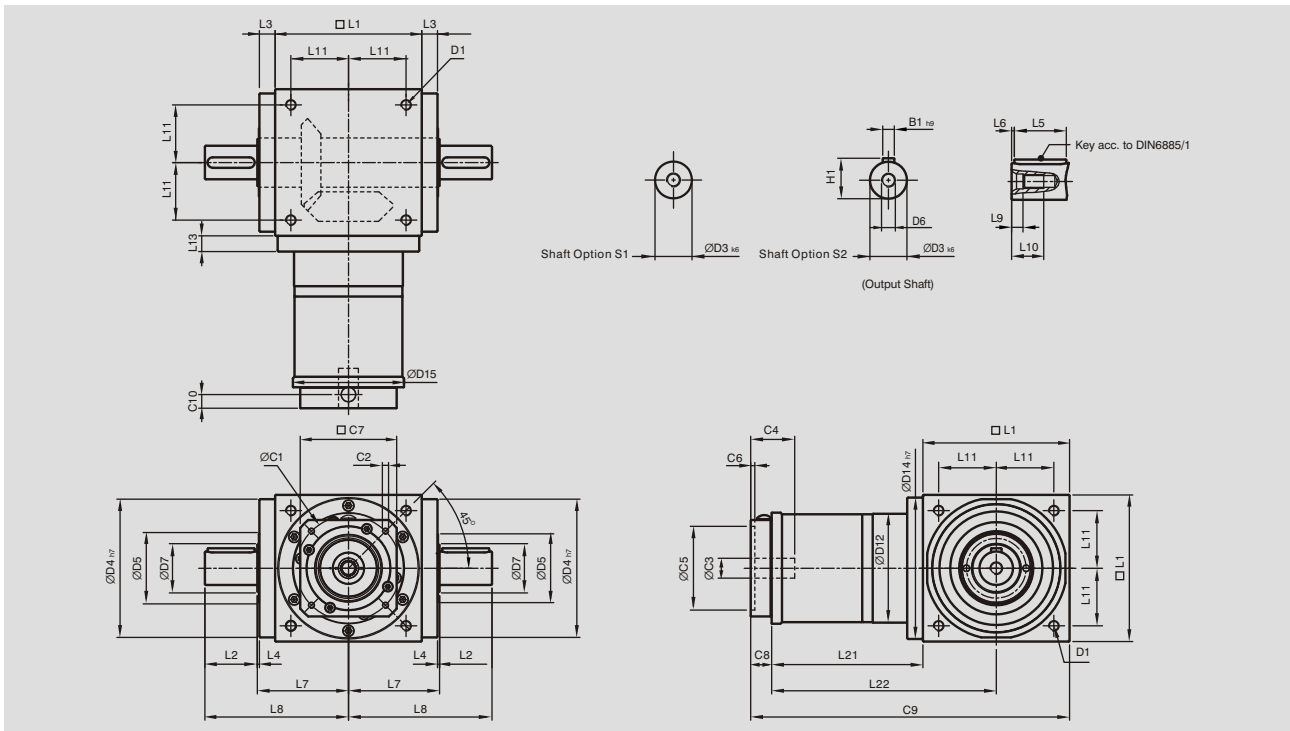

[unit: mm]

Dimension	AT065 FL	AT075 FL	AT090 FL	AT110 FL	AT140 FL	AT170 FL	AT210 FL	AT240 FL	AT280 FL
D1	M4	M6	M6	M8	M10	M12	M16	M16	M16
D3 <sub>k6</sub>	13	16	18	22	32	40	50	55	60
D4 <sub>h7</sub>	63	73	88	108	135	165	205	235	275
D5	31	35	43	53	68	83	104	124	144
D6	M4	M5	M5	M8	M12	M16	M16	M16	M20
D7	21	22	28	33	47	55	75	85	110
D12	62	72	86	106	104	128	160	180	200
D14 <sub>h7</sub>	63	73	88	108	135	165	205	235	275
D15	62.9	72.9	87	107	106	127	158	178	198
L1	65	75	90	110	140	170	210	240	280
L2	19.5	30	35	40	50	60	75	85	110
L3	13	14.5	15	15	15	15	20	25	25
L4	2	2	2	2	2	2	2	2	2
L5	16	25	28	32	45	50	70	80	100
L6	2	2.5	3.5	4	2.5	5	2.5	2.5	5
L7	47.5	54	62	72	87	102	127	147	167
L8	67	84	97	112	137	162	202	232	277
L9	4.5	4.8	4.8	7.2	10	12	12	12	15
L10	10	12.5	12.5	19	28	36	36	36	42
L11	27	30	36	44	55	67	85	95	110
L13	13	15	15	15	15	15	20	25	25
L21	75	84.5	99	122	144.5	157.5	206.5	239	248
L22	107.5	122	144	177	214.5	242.5	311.5	359	388
C1 <sup>4</sup>	46	46	70	100	100	100	130	165	165
C2 <sup>4</sup>	M4	M4	M5	M6	M6	M6	M8	M10	M10
C3 <sup>4</sup>	≤12	≤12	≤16	≤24	≤24	≤24	≤32	≤38	≤38
C4 <sup>4</sup>	30	30	34	40	40	40	50	60	60
C5 <sup>4</sup>	30	30	50	80	80	80	110	130	130
C6 <sup>4</sup>	3.5	3.5	8	4	4	4	5	6	6
C7 <sup>4</sup>	42	42	60	92	92	92	115	142	142
C8 <sup>4</sup>	21.5	21.5	21.5	20	20	20	24	31	31
C9 <sup>4</sup>	161.5	181	210.5	252	304.5	347.5	440.5	510	559
C10 <sup>4</sup>	14.5	14.5	15.5	13	13	13	16	21	21
B1 <sub>h9</sub>	5	5	6	6	10	12	14	16	18
H1	15	18	20.5	24.5	35	43	53.5	59	64

4. C1-C10 are motor specific dimensions (metric std shown). Refer to Apexdyna.com and Design Tool to view your specific motor mounting system.

# AT-FL Series

## Dimensions (3-stage, Ratio $i=75\sim 500$ )

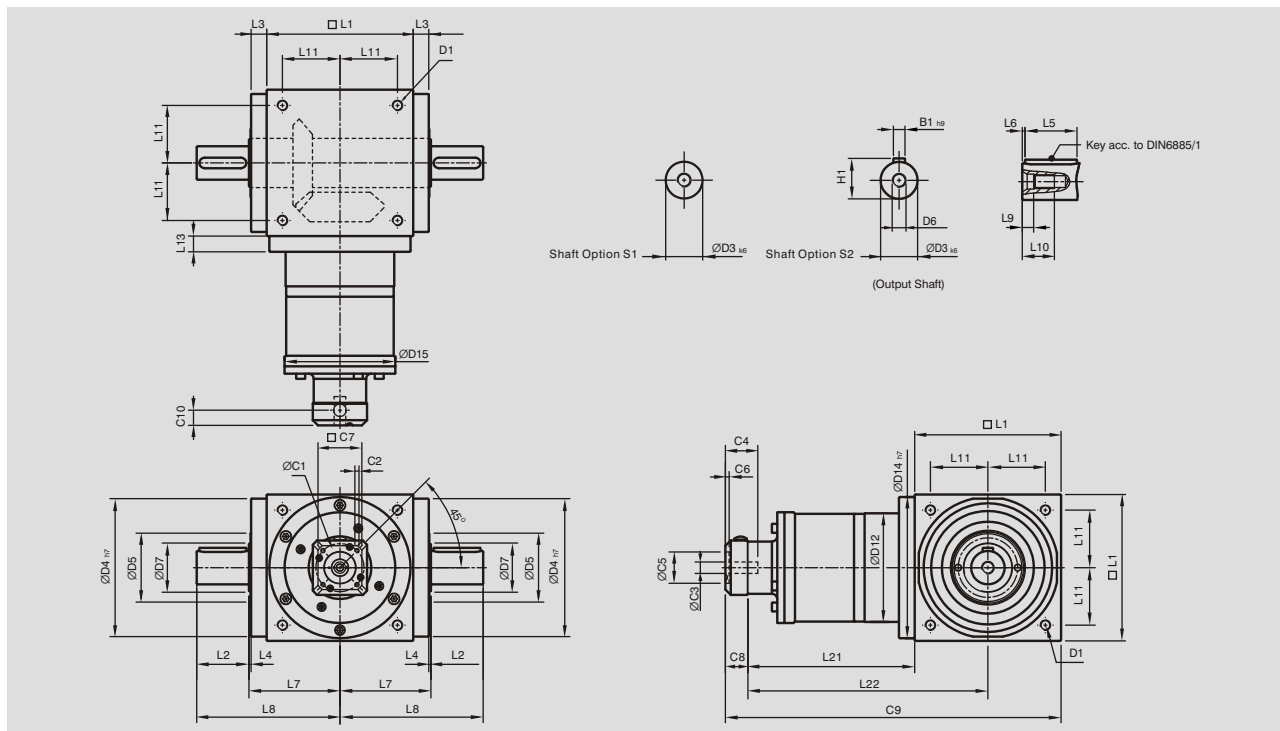

[unit: mm]

Dimension	AT110 FL	AT140 FL	AT170 FL	AT210 FL	AT240 FL	AT280 FL
D1	M8	M10	M12	M16	M16	M16
D3 <sub>k6</sub>	22	32	40	50	55	60
D4 <sub>h7</sub>	108	135	165	205	235	275
D5	53	68	83	104	124	144
D6	M8	M12	M16	M16	M16	M20
D7	33	47	55	75	85	110
D12	106	104	128	160	180	200
D14 <sub>h7</sub>	108	135	165	205	235	275
D15	107	106	127	158	178	198
L1	110	140	170	210	240	280
L2	40	50	60	75	85	110
L3	15	15	15	20	25	25
L4	2	2	2	2	2	2
L5	32	45	50	70	80	100
L6	4	2.5	5	2.5	2.5	5
L7	72	87	102	127	147	167
L8	112	137	162	202	232	277
L9	7.2	10	12	12	12	15
L10	19	28	36	36	36	42
L11	44	55	67	85	95	110
L13	15	15	15	20	25	25
L21	136.5	159.5	183.5	226	269	278
L22	191.5	229.5	268.5	331	389	418
C1 <sup>5</sup>	46	46	70	70	100	100
C2 <sup>5</sup>	M4	M4	M5	M5	M6	M6
C3 <sup>5</sup>	≤12	≤12	≤16	≤16	≤24	≤24
C4 <sup>5</sup>	30	30	34	34	40	40
C5 <sup>5</sup>	30	30	50	50	80	80
C6 <sup>5</sup>	3.5	3.5	8	8	4	4
C7 <sup>5</sup>	42	42	60	60	92	92
C8 <sup>5</sup>	21.5	21.5	21.5	21.5	20	20
C9 <sup>5</sup>	268	321	375	457.5	529	578
C10 <sup>5</sup>	14.5	14.5	15.5	15.5	13	13
B1 <sub>h9</sub>	6	10	12	14	16	18
H1	24.5	35	43	53.5	59	64

5. C1~C10 are motor specific dimensions (metric std shown). Refer to Apexdyna.com and Design Tool to view your specific motor mounting system.