



Full stainless gearbox

The full stainless steel planetary gearboxes [AERS series](#) is specially developed and constructed for use in food, pharmaceutical, chemical applications and those environments where corrosion protection is required.



True helical gear design

Precision helical gearing increases tooth-to-tooth contact ratio by over 33% vs spur gearing. The helix angle produces smooth and quiet operation with decreased backlash (less than 8 arc-minutes and $\leq 56\text{dB}$)



Triple split collet with dynamic balanced set collar clamping system

provides backlash-free power transmission and eliminates slippage. 100% concentricity allows for smooth rotation and higher input speed capability.



Lubricated with [Food Grade Grease](#) and sealed to [IP67](#) standards prevents leakage and is maintenance-free.



Whole piece planet carrier design

One-piece planet carrier with extended bearing design provides maximum radial load capacity and increases system reliability and stiffness.

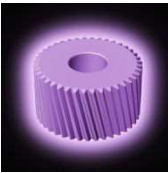

In-house plasma nitriding heat treatment

Our in-house plasma nitriding heat treatment process maintains the tooth surface hardness at [900Hv](#) for superior wear-resistance and a core hardness at [30HRc](#) for toughness.

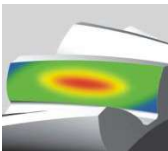

HeliTopo technology

A high setting gear performance is achieved by using our [HeliTopo Technology](#). This [eases off the tooth profile](#) and [crowns the lead of each tooth](#). This optimizes the gear mesh alignment and overlap to achieve maximum tooth surface contact.



Solid needle roller bearings without cage

Equipped with [solid uncaged needle roller bearings](#), provides maximum contact points to increase stiffness and transmit high output torque.

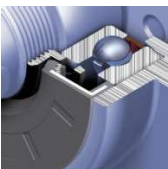

NEW - Patented output sealing systems design eliminates friction and heat generation which is accomplished by applying our hi-tech coating to all output contact surfaces. This coating reaches a hardness of [3700Hv](#) and is ground to Ra 0.2mm finish to ensure sealing.



NEW - Patented input sealing system design eliminates break-away torque and decreases friction/heat. The hi-tech coating bushing ([3700 Hv, Ra 0.2 mm finish](#)) interfaces with our proprietary seal which decreases wear and erosion of both sealing surfaces. This new patent prevents leakage and has a service life of over 20,000 hours.



[Patented planet carrier design](#) puts the sun gear bearing directly into the planet carrier. It minimizes gear misalignment to gain higher accuracy.

Specifications / AERS Series

Gearbox Performance

Model No.		Stage	Ratio ^A	AER050S	AER070S	AER090S	AER120S	AER155S
Nominal output torque T_{2N}	Nm	1	3	9	36	90	195	342
			4	12	48	120	260	520
			5	15	60	150	325	650
			6	18	55	150	310	600
			7	19	50	140	300	550
			8	17	45	120	260	500
			9	14	40	100	230	450
			10	14	60	150	325	650
			14	-	42	140	300	550
			20	-	40	100	230	450
		2	15	14	-	-	-	-
			20	14	-	-	-	-
			25	15	60	150	325	650
			30	20	55	150	310	600
			35	19	50	140	300	550
			40	17	45	120	260	500
			45	14	40	100	230	450
			50	14	60	150	325	650
			60	20	55	150	310	600
			70	19	50	140	300	550
80	17	45	120	260	500			
90	14	40	100	230	450			
100	14	40	100	230	450			
120	-	-	150	310	600			
140	-	-	140	300	550			
160	-	-	120	260	550			
180	-	-	100	230	450			
200	-	-	100	230	450			
Emergency Stop Torque T_{2NOT} ^B	Nm	1,2	3~200	3 times of nominal output torque				
Nominal Input Speed n_{1N}	rpm	1,2	3~200	5,000	5,000	4,000	4,000	3,000
Max. Input Speed n_{1B}	rpm	1,2	3~200	10,000	10,000	8,000	8,000	6,000
Backlash	arcmin	1	3~20	≤10	≤10	≤10	≤10	≤10
		2	25~200	≤14	≤14	≤14	≤14	≤14
Torsional Rigidity	Nm/arcmin	1,2	3~200	3	7	14	25	50
Max. Radial Load F_{2RB} ^C	N	1,2	3~200	702	1,377	2,985	6,100	8,460
Max. Axial Load F_{2aB} ^C	N	1,2	3~200	390	765	1,625	3,350	4,700
Efficiency η	%	1	3~20	≥95%				
		2	25~200	≥92%				
Weight	kg	1	3~20	1.0	2.1	5.8	11.2	22.4
		2	25~200	1.3	2.0	4.6	11.1	21.8
Operating temp	°C	1,2	3~200	-10°C~90°C				
Lubrication				Synthetic lubrication oils				
Degree of gearbox protection		1,2	3~200	IP67				
Mounting position		1,2	3~200	All directions				
Noise ^D	dB(A)	1,2	3~200	≤61	≤63	≤65	≤68	≤70

Gearbox Inertia

Model No.		Stage	Ratio ^A	AER050S	AER070S	AER090S	AER120S	AER155S
Mass Moments of Inertia J_1	kg · cm ²	1	3~10	0.09	0.35	2.25	6.84	23.4
			14	-	0.07	1.87	6.25	21.8
			20	-	0.07	1.87	6.25	21.8
		2	15	0.09	-	-	-	-
			20	0.09	-	-	-	-
			25~100	0.09	0.09	0.35	2.25	6.84
120~200	-	-	0.31	1.87	6.25			

A. Ratio ($i=N_{in}/N_{out}$)

B. Max. acceleration torque $T_{2B} = 60\%$ of T_{2NOT}

C. Applied to the output shaft center at 100 rpm

D. The dB values are measured by gearbox with ratio 10 (1-stage) or ratio 100 (2-stage), no loading at 3,000 RPM or at the respective Nominal Input Speed by bigger model size.

By lower ratio and/or higher RPM, the noise level could be 3 to 5 dB higher.

E. 5 years warranty.

Dimensions (1-stage, Ratio $i=3\sim 20$) / AERS Series

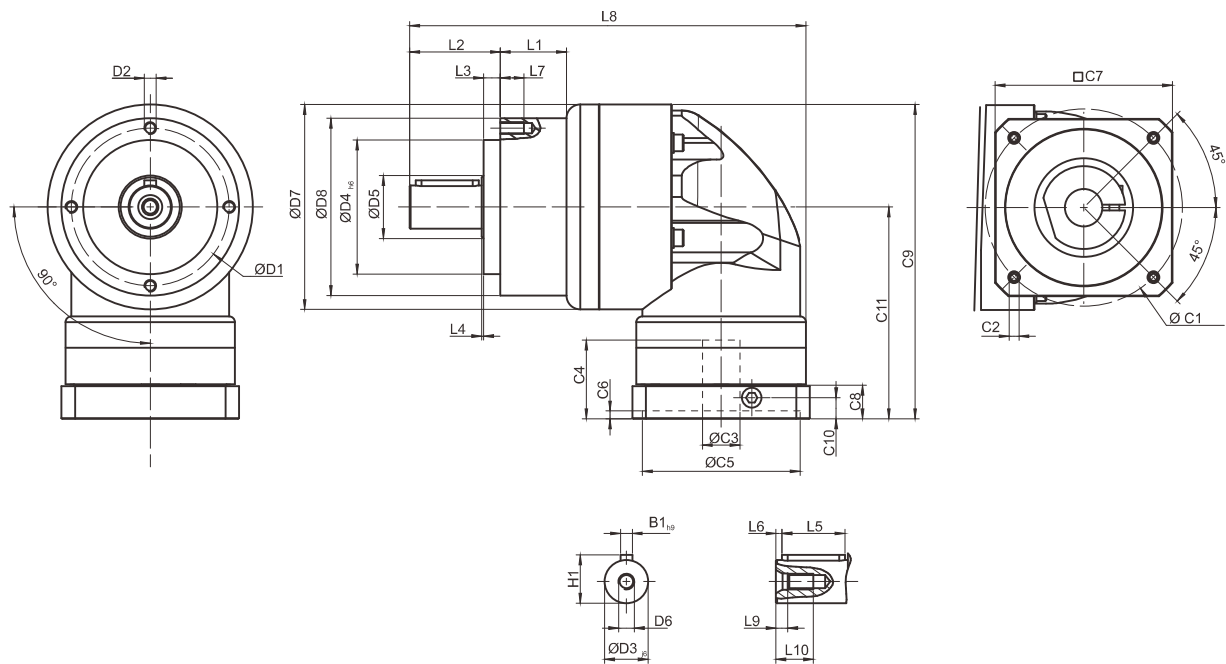

[unit: mm]

Dimension	AER050S	AER070S	AER090S	AER120S	AER155S
D1	44	62	80	108	140
D2	M4 x 0.7P	M5 x 0.8P	M6 x 1P	M8 x 1.25P	M10 x 1.5P
D3 _{j6}	12	16	22	32	40
D4 _{h6}	35	52	68	90	120
D5	22	22	30	40	75
D6	M4 x 0.7P	M5 x 0.8P	M8 x 1.25P	M12 x 1.75P	M16 x 2P
D7	53	70	104	130	162
D8	50	70	90	120	155
L1	--	--	33.5	38	50
L2	24.5	36	46	70	97
L3	4	6.5	8.5	17.5	15
L4	1	1	1	1.5	3
L5	14	25	32	40	63
L6	2	2	3	5	5
L7	8	10	12	16	20
L8	115.5	148.5	201	252	324.5
L9	4.5	4.8	7.2	10	12
L10	10	12.5	19	28	36
C1 ¹	46	75	100	145	165
C2 ¹	M4 x 0.7P	M5 x 0.8P	M6 x 1P	M8 x 1.25P	M10 x 1.5P
C3 ¹	≤11 / ≤12	≤14 / ≤16	≤19 / ≤24	≤32	≤38
C4 ¹	26	30	43	55	71
C5 ¹	30	60	80	110	130
C6 ¹	4.5	4	7.5	6	7.5
C7 ¹	40	70	90	130	179
C8 ¹	17.5	18	20	24	32.5
C9 ¹	100.5	116.5	159.5	199	245.5
C10 ¹	10.3	12.5	13.8	17.5	25
C11 ¹	71	77.5	110.5	138.5	174.5
B1 _{h9}	4	5	6	10	12
H1	14	18	24.5	35	43

1. C1~C11 are motor specific dimensions (metric std shown).

Refer to www.apexdyna.com and Design Tool to view your specific motor mounting system.

Dimensions (2-stage, Ratio $i=15\sim 200$) / AERS Series

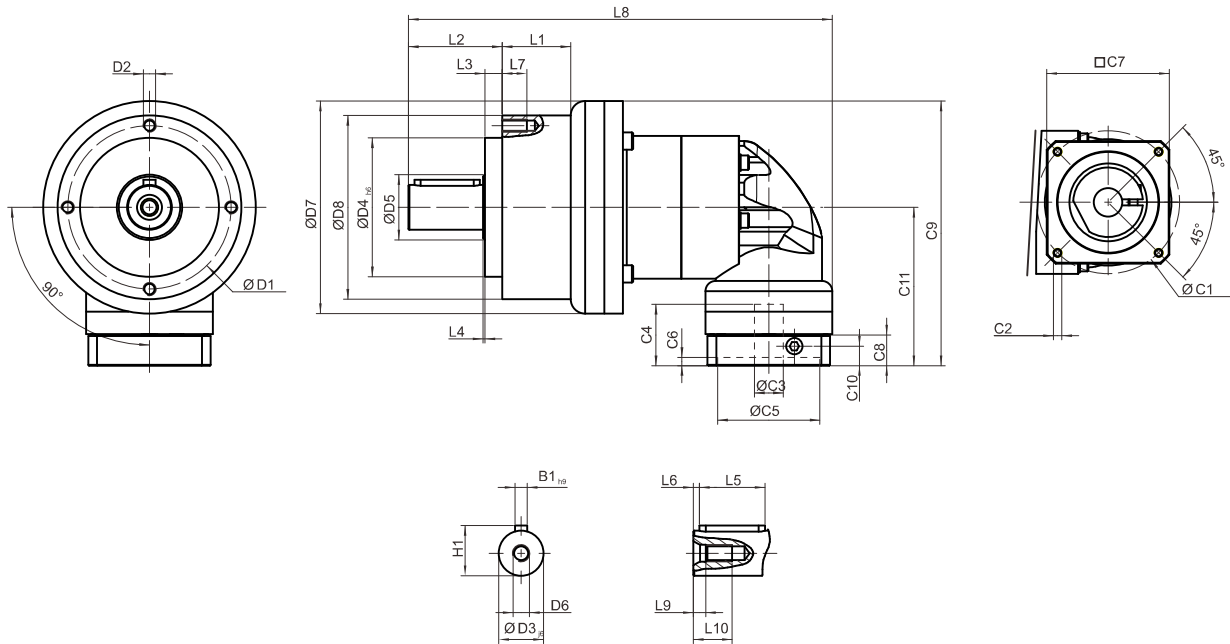

[unit: mm]

Dimension	AER050S	AER070S	AER090S	AER120S	AER155S
D1	44	62	80	108	140
D2	M4 x 0.7P	M5 x 0.8P	M6 x 1P	M8 x 1.25P	M10 x 1.5P
D3 _{j6}	12	16	22	32	40
D4 _{h6}	35	52	68	90	120
D5	22	22	30	40	75
D6	M4 x 0.7P	M5 x 0.8P	M8 x 1.25P	M12 x 1.75P	M16 x 2P
D7	53	70	104	130	162
D8	50	70	90	120	155
L1	--	--	33.5	38	50
L2	24.5	36	46	70	97
L3	4	6.5	8.5	17.5	15
L4	1	1	1	1.5	3
L5	14	25	32	40	63
L6	2	2	3	5	5
L7	8	10	12	16	20
L8	142.5	167.5	210	283	358
L9	4.5	4.8	7.2	10	12
L10	10	12.5	19	28	36
C1 ²	46	63	75	90	145
C2 ²	M4 x 0.7P	M5 x 0.8P	M5 x 0.8P	M6 x 1P	M8 x 1.25P
C3 ²	≤11 / ≤12	≤11 / ≤12	≤14 / ≤15.875 / ≤16	≤19 / ≤24	≤32
C4 ²	26	24.5	30	42	55
C5 ²	30	40	60	70	110
C6 ²	45	3	4	6	6
C7 ²	40	55	70	80	130
C8 ²	17.5	16	18	19	24
C9 ²	98.3	104.5	129.5	174.5	219.5
C10 ²	10.3	8.8	12.5	12.8	17.5
C11 ²	71	69.5	77.5	109.5	138.5
B1 _{h9}	4	5	6	10	12
H1	14	18	24.5	35	43

2. C1-C11 are motor specific dimensions (metric std shown).

Refer to www.apexdyna.com and Design Tool to view your specific motor mounting system.